

PRELIMINARY



321 kW



70 t



56.9 m



MAXCAB

670E

Heavy duty cycle crawler crane

Emissions level IV

670E Advanced. Versatile – dynamic – robust



1969: First full hydraulic duty cycle crawler crane worldwide, SK 15

What makes up the E-Series

- 60 years of experience in the design and construction of duty cycle crawler cranes
- Uncompromisingly high performance in all areas
- Technology that can be mastered: High-quality components without over-engineering
- Long product service life and high value retention

Your top benefits:

1 Green Efficiency
Save fuel – reduce operating costs
Work quietly – protect operator and environment



2 Peak performance
Durable mechanical systems – stressed parts optimized
High speeds – high load capacities

3 Maximum operating comfort
Comfortable Maxcab operator cab – relaxed work
SENCON – SENNEBOGEN Control System



4 Flexibility in use
Driving under load – low space requirement
Strong undercarriage traction – good all-terrain mobility

5 Easy transport
Telescopic undercarriage – quickly ready for use
Ballast support system – short set-up time

6 Maintenance and service made easy
Easy fault diagnosis – central measuring points
Easy maintenance – clear labeling

7 Consultation and support
3 production sites – 2 subsidiaries
120 sales partners – over 300 service stations

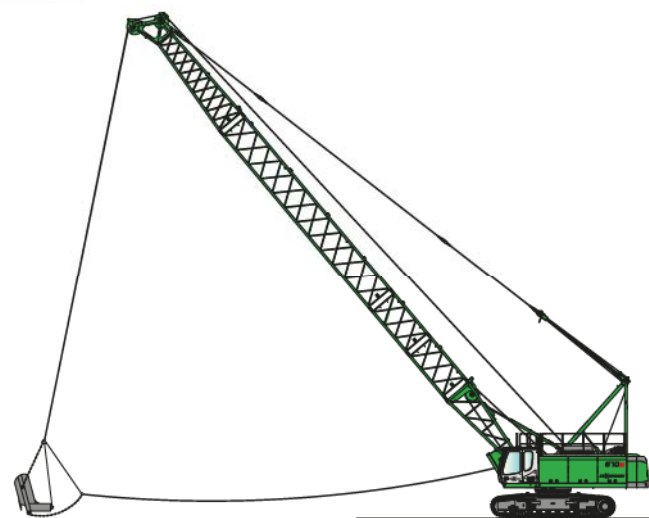

Dragline bucket equipment

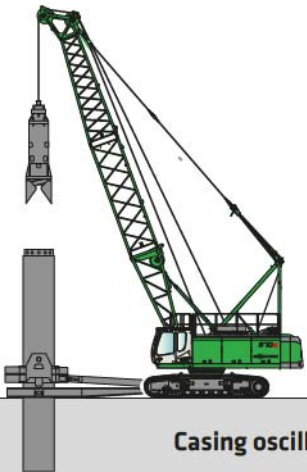

Casing oscillator



Diaphragm wall grab

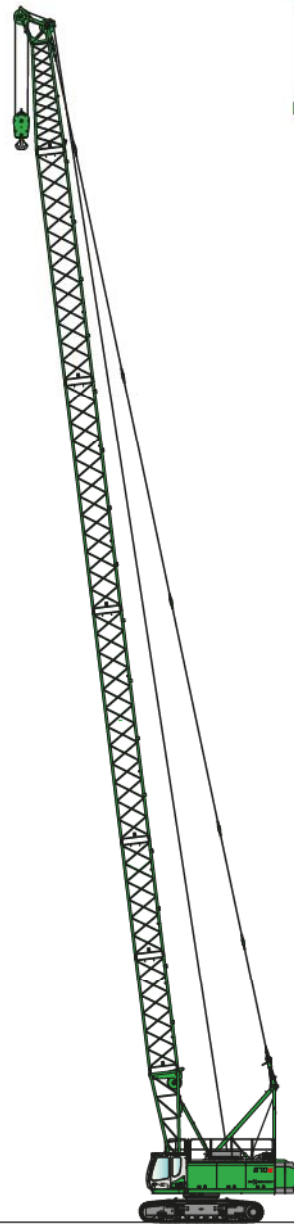

Crane equipment

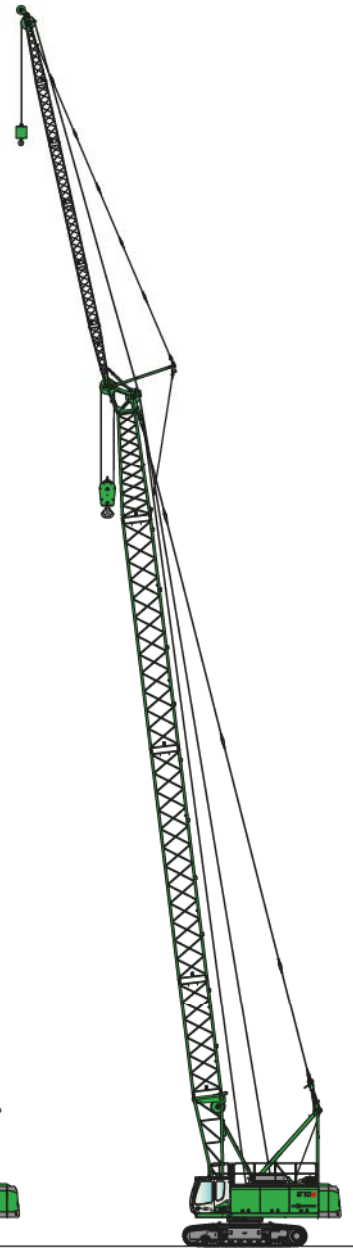

Crane equipment with fixed fly

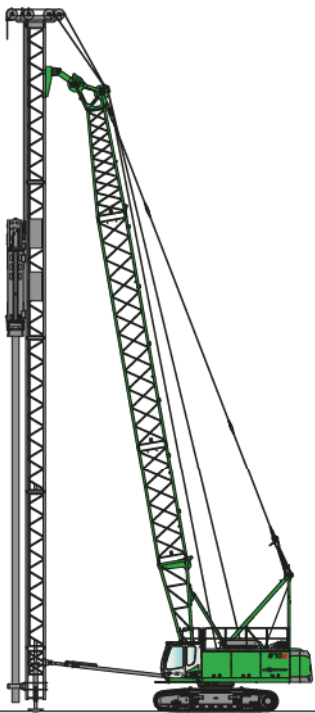

Leaders

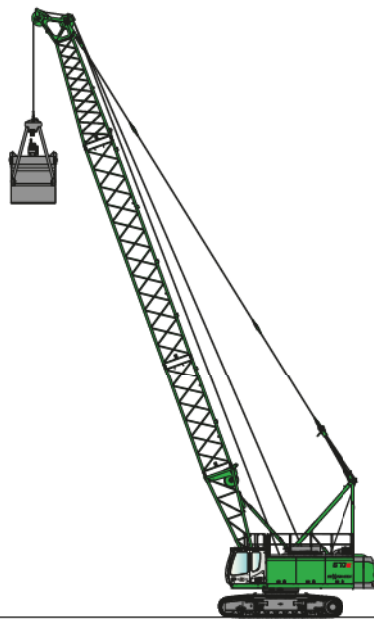

Grab equipment

MACHINE TYPE

Model (type) **670**

ENGINE

Power **Cummins QSM 298 kW / 405 hp at 1800 min⁻¹ (TIER IIIa)**
Cummins QSG12 261 kW / 355 hp at 1800 min⁻¹ (TIER IVf)
Cummins QSG12 321 kW / 436 hp at 1800 min⁻¹ (TIER IVf)
 Direct injection, turbo-charged, charge air cooling, reduced emissions

Cooling Water-cooled

Air filter Dry filter with pre-separator, automatic dust discharge, main element and safety element, contamination indicator

Fuel tank **690 l**

Electr. system **24 V**

Batteries **2 x 180 Ah, main switch**

Options

- Idle/Stop Automatic

UPPERCARRIAGE

Design Torsion-resistant box design, precision crafted, bronze bushings for boom bearing arrangement

Clear, service-friendly concept, engine installed in the longitudinal direction

Lighting LED headlights for optimal illumination of the work area

Safety Camera monitoring of the rear area and right side

Options

- Low-temperature package for use at temperatures below -20 °C
- Ballast support fixture
- Pinion tooth lubrication for slewing ring, outer
- Automatic central lubrication system for equipment and slewing ring, inner
- Walkways left and right on the uppercarriage
- Maritime climate varnishing

HYDRAULIC SYSTEM

Multi-circuit hydraulic system for optimal function and capacity, all movements can be run simultaneously. The hydraulic pumps are variable displacement piston pumps with individual control and energy-saving flow-on-demand control. The pumps only supply as much oil as is actually consumed. Pressure cut-off, load limit sensing control

Operating pressure **max. 330 bar**

Filtration High-performance filtration with long-term change interval, contamination level indicator

Hydraulic tank **790 l (680 l to the middle of the sight glass)**

Control system Proportional, precision hydraulic servo control of the movements, 2 servo joysticks for work functions, supplemental functions via switches and foot pedals – arranged clearly and ergonomically

Options

- Bio-oil – environmentally friendly
- SENNEBOGEN HydroClean micro-filter system with water separator
- Potentiometer for casing machine and other attachments
- Grapple fill automation
- Supplemental hydraulic system with 1 x 220 l/min

SLEWING DRIVE

Gearbox 2x compact planetary gears with slant axis hydraulic motor, integrated brake valves - precision slewing gear brake

Parking brake Spring-loaded multi-disk brake

Slewing ring Ball bearing rotary connection with exterior gearing

Slewing speed 0-4.0 rpm, 3 adjustable rotation speeds

Options

- Reinforced slewing ring for heavy, dynamic inserts

CAB MAX CAB

Cab type Maxcab rigid

Cab equipment Sliding door, excellent ergonomics, climate automation, seat heater, air-suspension comfort seat, fresh air filter / circulating air filter, joystick steering, 12 V / 24 V connections, SENCON, roof window

Options

- Cab type E270, can be elevated 270 cm
- Cab can be tilted 15°
- Auxiliary heating system with timer
- Cabs with active carbon filter inside/ outside air
- Sliding window in operator door
- Armored-glass windshield
- Armored-glass sunroof
- Safety side window and rear window
- Sunblind for windshield
- Protective roof grating
- FOPS protective roof grating
- Protective front grating
- Radio with speakers

ATTACHMENTS

Design	Decades of experience and the latest computer simulations guarantee the greatest degree of stability and longest service life
Boom adjustment winch	Drive via slant axis hydraulic motor with compact planetary gear, pulling force 52 kN, rope diameter 14 mm, adjustment speed 15° to 81° in approx. 48 seconds.
Safety brake	Spring-loaded multi-disk brake
Boom	Boom length to 56.9 m
Options	<ul style="list-style-type: none"> ■ Auxiliary jib, for load ratings to 12 t ■ Fixed fly to 18 m ■ Steel rope sheaves ■ Jib sheaves for grapple implementation ■ HD sheaves for working with optimal rope guide ■ Load moment limitation for hoisting implementation: latest generation of load moment monitoring, display shows all important data, lifting limit switch, pressure relief valves, rope run-out safeguard

UNDERCARRIAGE

Design	Extremely strong crawler undercarriage, type T83/390 with hydraulically extendible track width. Stable welded construction.
Drive	Strong travel drive with axial piston hydraulic motor and directly attached automatically functioning brake valve and compact planetary gear on each running gear side; protected drive transmission
Parking brake	Spring-loaded multi-disk brake
Traveling gear	Maintenance-free tractor running gear B7 with hydraulic chain tension, 700 mm 3-grouser base plates,
Speed	0 - 1.9 km/h
Options	<ul style="list-style-type: none"> ■ 700 mm flat base plates (transport width 3000 mm) ■ 800 mm 3-grouser base plates (transport width 3200 mm)

WINCH

The winches are driven via high-pressure-regulated adjustable hydraulic motors, thus there is always optimal pulling force speed control. Hydraulic lowering brake valves for sensitive, wear-free braking. Strong oil-bath planetary gear, low-maintenance.

Crane and free fall brakes are spring-loaded, maintenance-free, low-wear disc brakes running in the oil bath, oil-cooled. The driver is assisted by the special, continuously-variable free fall brake that also helps to protect the machine.

	Series production	Option
Winches	16 t	20 t
Rope winch (rated load) 1st layer	160 kN	200 kN
Rope diameter	26 mm	28 mm
Rope speed	0-125 m/min	0-110 m/min

Options	<ul style="list-style-type: none"> ■ Grapple steadying winch 9 kN ■ Grapple steadying winch 18 kN ■ Grapple steadying winch 30 kN ■ Rope tensioning pulley
---------	--

OPERATING WEIGHT

Mass **approx. 70 t**

670 R with 2 x 16 t freefall winches, basic boom 12.1 m, counterweight 22 t, 60 t bottom hook block, 700 mm 3-grouser base plates, 150 m hoisting rope

Notice The operating weight varies depending on the version and equipment.

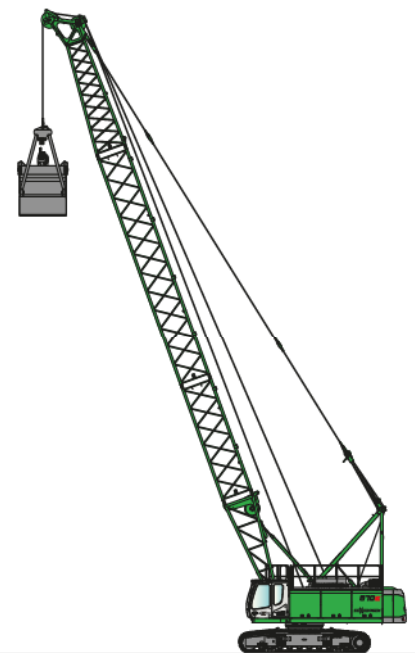

670E Main boom

HD

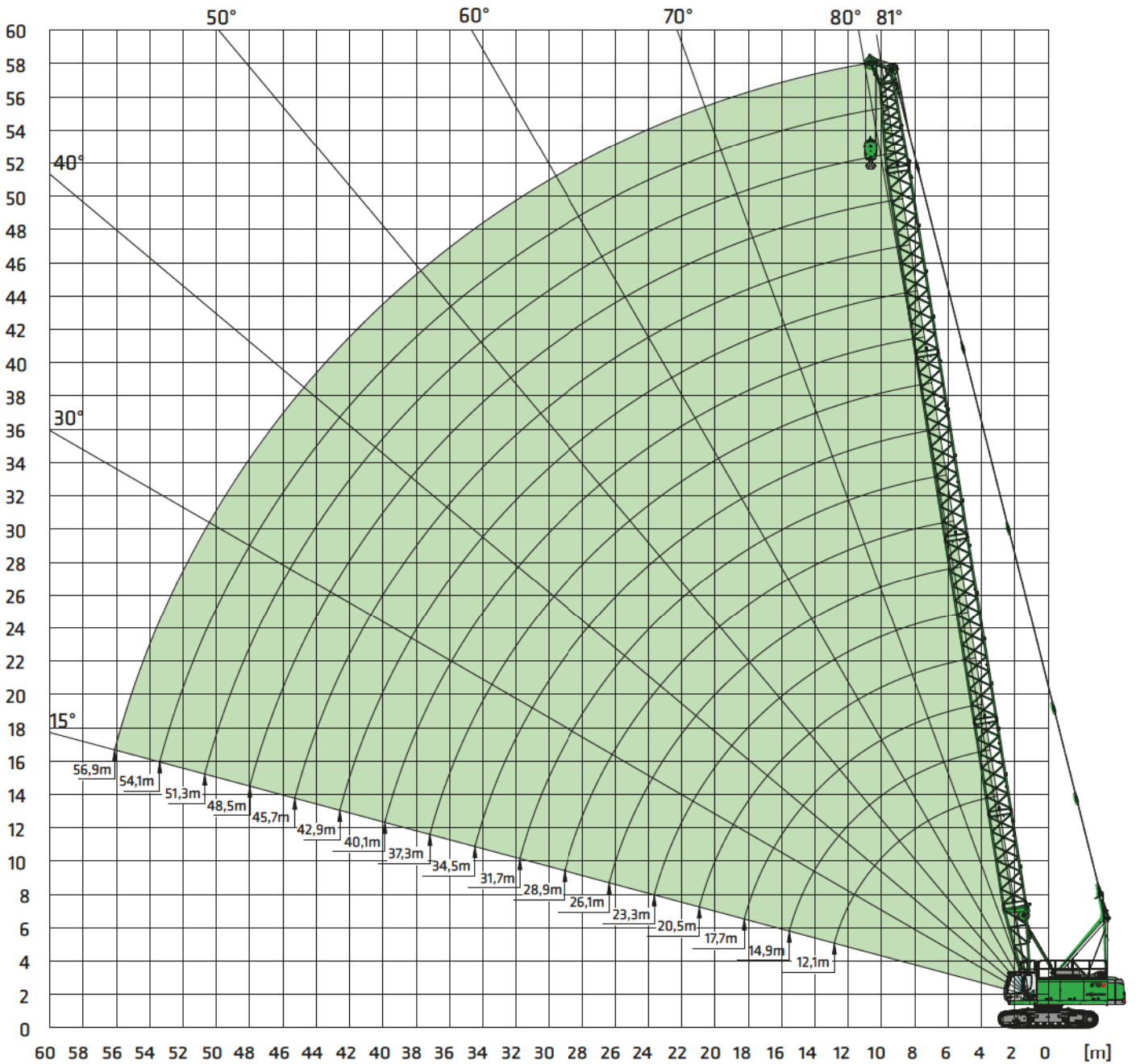

Boom configuration

Boom length	12.1	14.9	17.7	20.5	23.3	26.1	28.9	31.7	34.5	37.3	40.1	42.9	45.7	48.5	51.3	54.1	56.9
Lower boom section type 1442	5.5 j/m	1	1	1	1	1	1	1	1	1	1	1	1	1	1	1	1
Boom section type 1442	2.8 j/m	0	1	0	1	0	1	0	1	0	1	0	1	0	1	0	1
Boom section type 1442	5.6 j/m	0	0	1	1	2	2	1	1	2	2	1	1	2	2	1	1
Boom section type 1442	11.2 j/m	0	0	0	0	0	0	1	1	1	1	2	2	2	3	3	3
Head piece type 1442	6.6 j/m	1	1	1	1	1	1	1	1	1	1	1	1	1	1	1	1
Auxiliary jib S12.4 (option)	12.0 t	x	x	x	x	x	x	x	x	x	x	x	x	x	x	x	x

670E Fixed fly boom

HD

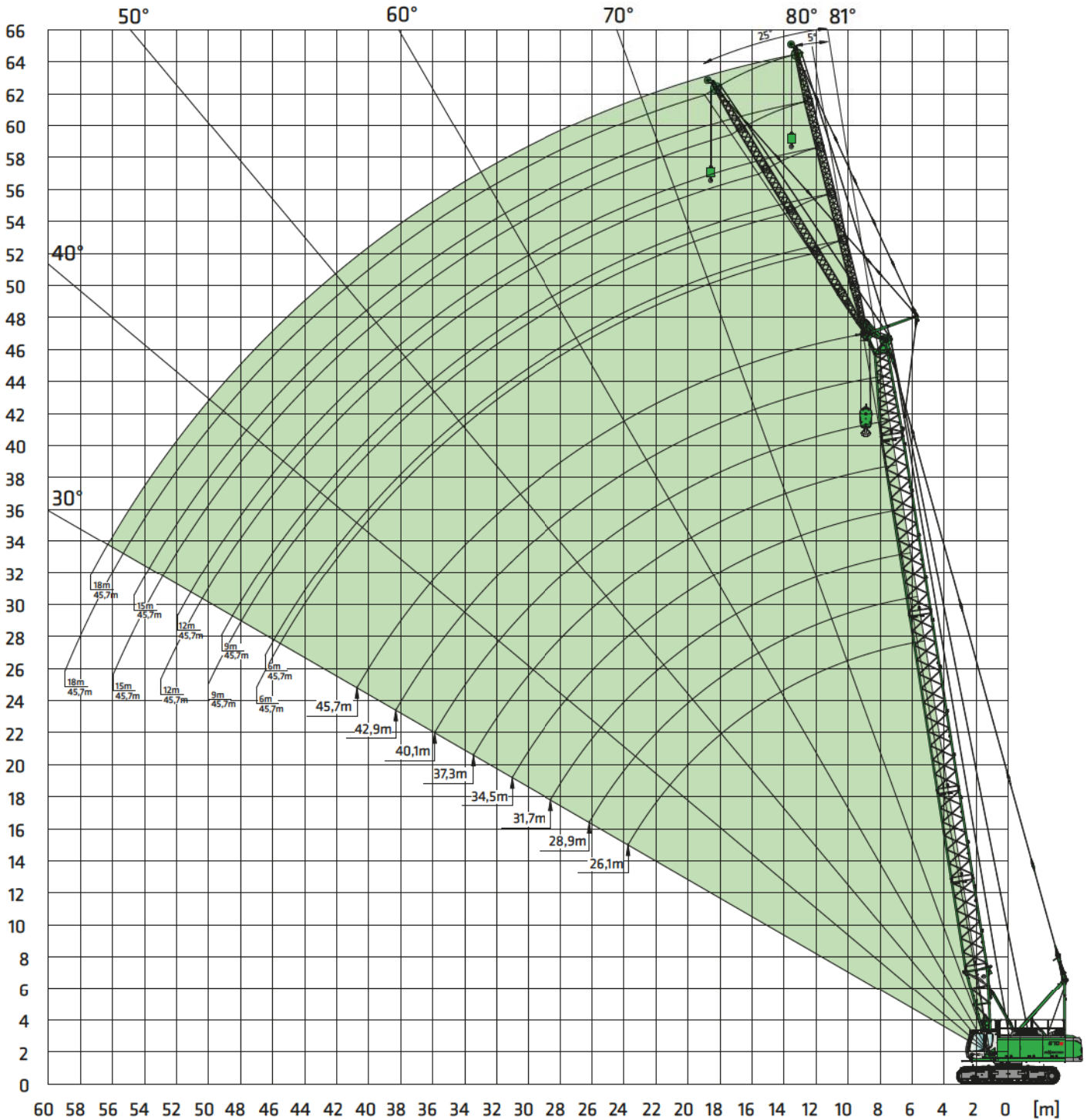

8 Technical features and dimensions subject to change.



Main boom with fixed fly SHFS

		Boom configuration												
		Main boom								Fixed fly jib				
Boom length		26.1	28.9	31.7	34.5	37.3	40.1	42.9	45.7	6.0	9.0	12.0	15.0	18.0
Lower boom section, type 1442	5.5 j/m	1	1	1	1	1	1	1	1					
Intermediate boom section, type 1442	2.8 j/m	1	0	1	0	1	0	1	0					
Intermediate boom section, type 1442	5.6 j/m	2	1	1	2	2	1	1	2					
Intermediate boom section, type 1442	11.2 j/m	0	1	1	1	1	2	2	2					
Boom headpiece, type 1442	5.9 j/m	1	1	1	1	1	1	1	1					
Fly boom lower section type 598	3.0 j/m									1	1	1	1	1
Fly boom intermediate section, type 598	3.0 j/m									0	1	2	3	4
Fly boom head piece, type 598	3.0 j/m									1	1	1	1	1

Combination possibilities SHFS

		Boom configuration							
Fixed fly jib length		Main boom							
		26.1	28.9	31.7	34.5	37.3	40.1	42.9	45.7
6.0 j/m		x	x	x	x	x	x	x	x
9.0 j/m		x	x	x	x	x	x	x	x
12.0 j/m		x	x	x	x	x	x	x	x
15.0 j/m		x	x	x	x	x	x	x	x
18.0 j/m		x	x	x	x	x	x	x	x

X = possible configuration



Hook

For 160 kN winches with 26 mm rope diameter

Capacity	Weight	Rope strands and maximum load rating [kg]					
		6	5	4	3	2	1
15 t	300 kg						12,000
40 t 1-pulley	500 kg				36,000	24,000	12,000
60 t 2-pulley	600 kg		60,000	48,000	36,000	24,000	12,000
80 t 3-pulley	1000 kg	70,000	60,000	48,000	36,000	24,000	12,000

For 200 kN winches with 28 mm rope diameter

Capacity	Weight	Rope strands and maximum load rating [kg]					
		6	5	4	3	2	1
15 t	350 kg						14,000
40 t 1-pulley	550 kg				40,000	28,000	14,000
70 t 2-pulley	900 kg		70,000	56,000	42,000	28,000	14,000

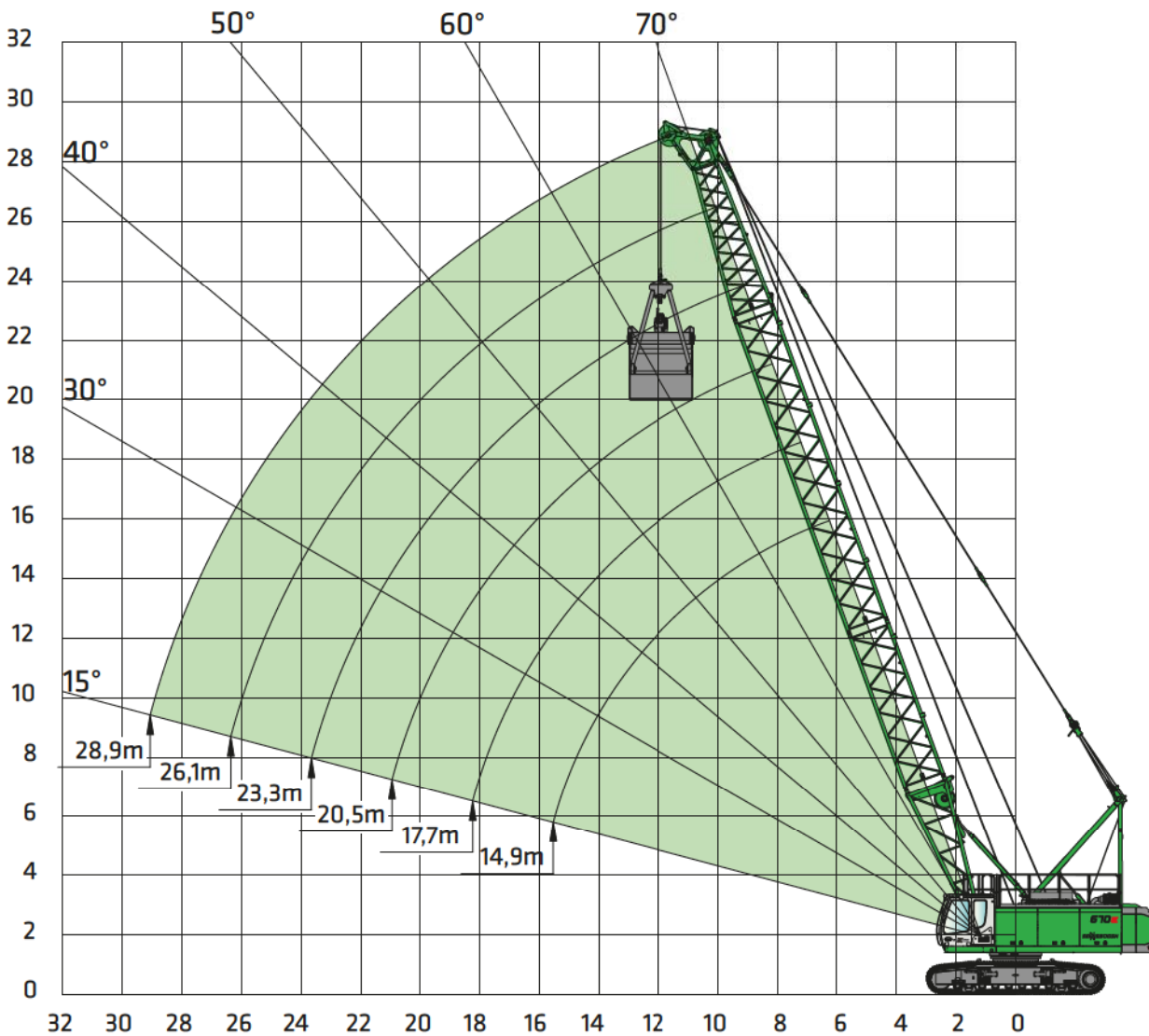

Comments:

1. The specified safe working load values apply to ensure level and firm standing of the machine.
2. The safe working load values are specified in tons (t) and apply for 360 degrees.
3. The safe working loads apply for the maximum outrigger width/undercarriage track width of 3840 mm
4. The specified safe working loads include the grapple weight and do not exceed 66.7% of the tipping load

5. For operation with a mechanical two-rope grapple and even load distribution on the closing and holding ropes, the safe working load is limited by the permissible rope tension or the maximum winch pulling force of a winch:

Winch pulling force [kN]	160	200
Rope diameter [mm]	26	28
Minimum tensile strength [kN]	568	710
Maximum safe working load in single-winch operation [t]	16.0	12.0
Maximum safe working load in two-winch operation [t]	24.2	30.3

22 t	Boom length [m]																	
	14.9			17.7			20.5			23.3			26.1			28.9		
	R	H	t	R	H	t	R	H	t	R	H	t	R	H	t	R	H	t
70	6.8	15.7	29.5	7.8	18.4	24.3	8.7	21.0	20.5	9.7	23.6	17.7	10.6	26.3	15.4	11.6	28.9	13.7
65	8.0	15.2	23.4	9.2	17.7	19.2	10.4	20.3	16.2	11.5	22.8	13.9	12.7	25.3	12.1	13.9	27.9	10.7
60	9.1	14.5	19.5	10.5	17.0	16.0	11.9	19.4	13.4	13.3	21.8	11.4	14.7	24.2	9.9	16.1	26.7	8.7
55	10.2	13.8	16.7	11.8	16.1	13.7	13.4	18.4	11.4	15.0	20.7	9.7	16.6	23.0	8.4	18.2	25.3	7.3
50	11.2	13.0	14.7	13.0	15.1	12.0	14.8	17.3	10.0	16.6	19.4	8.5	18.4	21.6	7.2	20.2	23.7	6.3
45	12.1	12.1	13.3	14.1	14.0	10.8	16.1	16.0	8.9	18.0	18.0	7.6	20.0	20.0	6.4	22.0	22.0	5.6
40	12.9	11.1	12.1	15.1	12.9	9.8	17.2	14.7	8.1	19.4	16.5	6.8	21.5	18.3	5.8	23.7	20.1	5.0
35	13.7	10.0	11.3	16.0	11.6	9.1	18.3	13.2	7.5	20.6	14.8	6.3	22.9	16.4	5.3	25.2	18.0	4.6
30	14.4	8.9	10.6	16.8	10.3	8.6	19.2	11.7	7.0	21.6	13.1	5.9	24.1	14.5	4.9	26.5	15.9	4.2
25	14.9	7.7	10.1	17.4	8.9	8.1	20.0	10.1	6.7	22.5	11.2	5.5	25.1	12.4	4.6	27.6	13.6	4.0
20	15.4	6.5	9.7	18.0	7.4	7.8	20.6	8.4	6.4	23.3	9.3	5.3	25.9	10.3	4.4	28.5	11.3	3.8
15	15.7	5.2	9.4	18.4	5.9	7.6	21.1	6.7	6.2	23.8	7.4	5.1	26.5	8.1	4.3	29.2	8.8	3.6

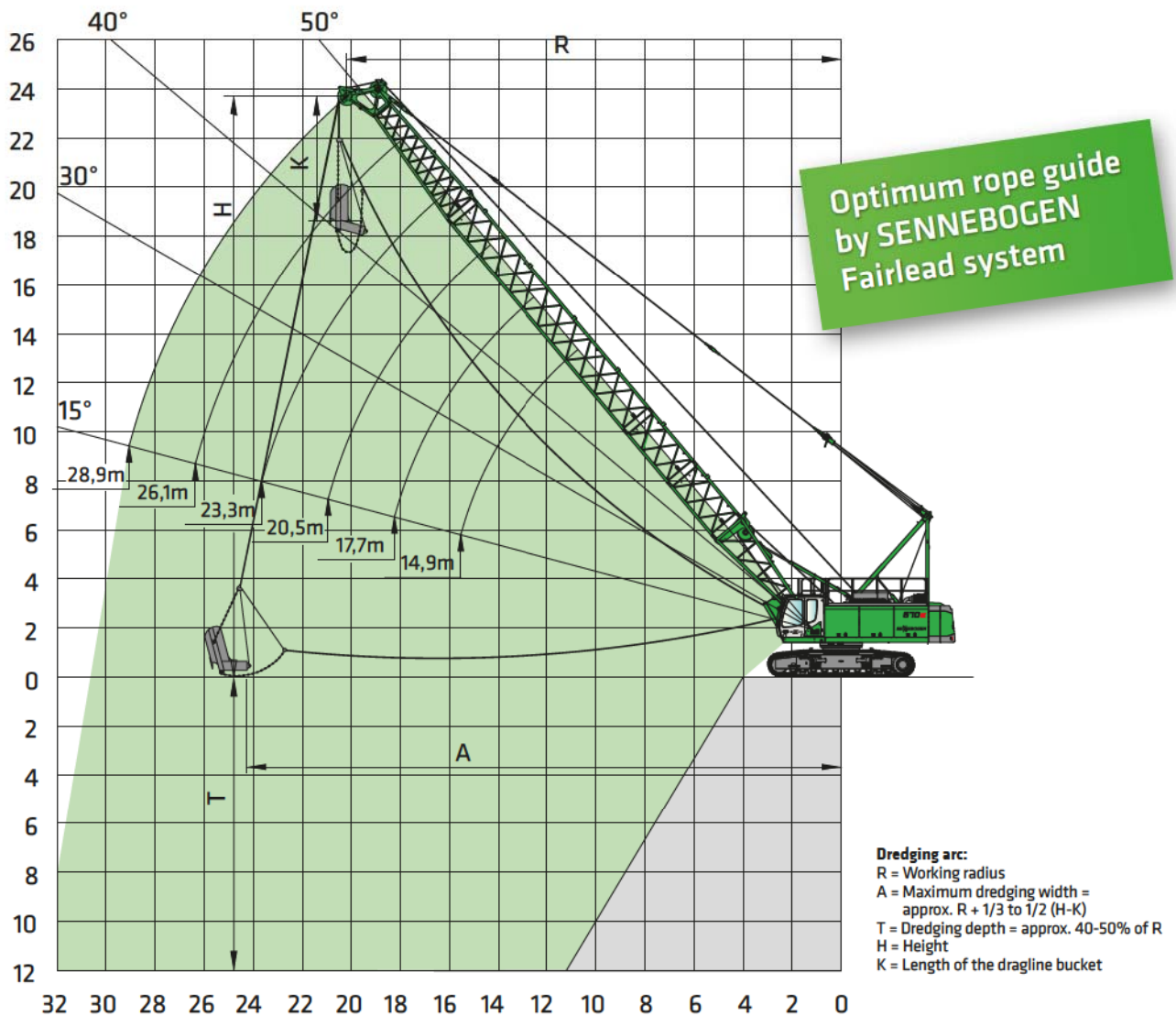

Comments:

- The specified safe working load values apply to ensure level and firm standing of the machine.
- The safe working load values are specified in tons (t) and apply for 360 degrees.
- The safe working loads apply for the maximum outrigger width / undercarriage track width of 3840 mm.
- The specified safe working loads include the weight of the dragline bucket and do not exceed 75% of the tipping load.
- The safe working load is limited by the maximum rope winch or by the maximum winch pulling force of a winch

Winch pulling force [kN]	160	200
Rope diameter [mm]	26	28
Minimum tensile strength [kN]	568	710
Maximum safe working load in drag bucket operation [t]	16.0	12.0

Boom angle alpha [°]	Boom length [m]																	
	14.9			17.7			20.5			23.3			26.1			28.9		
	R	H	t	R	H	t	R	H	t	R	H	t	R	H	t	R	H	t
70	6.8	15.7	33.2	7.8	18.4	27.3	8.7	21.0	23.1	9.7	23.6	19.9	10.6	26.3	17.4	11.6	28.9	15.4
65	8.0	15.2	26.3	9.2	17.7	21.6	10.4	20.3	18.2	11.5	22.8	15.6	12.7	25.3	13.6	13.9	27.9	12.0
60	9.1	14.5	21.9	10.5	17.0	17.9	11.9	19.4	15.1	13.3	21.8	12.9	14.7	24.2	11.1	16.1	26.7	9.8
55	10.2	13.8	18.8	11.8	16.1	15.4	13.4	18.4	12.9	15.0	20.7	10.9	16.6	23.0	9.4	18.2	25.3	8.2
50	11.2	13.0	16.6	13.0	15.1	13.5	14.8	17.3	11.3	16.6	19.4	9.5	18.4	21.6	8.2	20.2	23.7	7.1
45	12.1	12.1	14.9	14.1	14.0	12.1	16.1	16.0	10.1	18.0	18.0	8.5	20.0	20.0	7.2	22.0	22.0	6.3
40	12.9	11.1	13.7	15.1	12.9	11.1	17.2	14.7	9.2	19.4	16.5	7.7	21.5	18.3	6.5	23.7	20.1	5.6
35	13.7	10.0	12.7	16.0	11.6	10.3	18.3	13.2	8.4	20.6	14.8	7.1	22.9	16.4	6.0	25.2	18.0	5.1
30	14.4	8.9	11.9	16.8	10.3	9.6	19.2	11.7	7.9	21.6	13.1	6.6	24.1	14.5	5.5	26.5	15.9	4.8
25	14.9	7.7	11.3	17.4	8.9	9.1	20.0	10.1	7.5	22.5	11.2	6.2	25.1	12.4	5.2	27.6	13.6	4.5
20	15.4	6.5	10.9	18.0	7.4	8.8	20.6	8.4	7.2	23.3	9.3	6.0	25.9	10.3	5.0	28.5	11.3	4.3
15	15.7	5.2	10.6	18.4	5.9	8.5	21.1	6.7	6.9	23.8	7.4	5.8	26.5	8.1	4.8	29.2	8.8	4.1

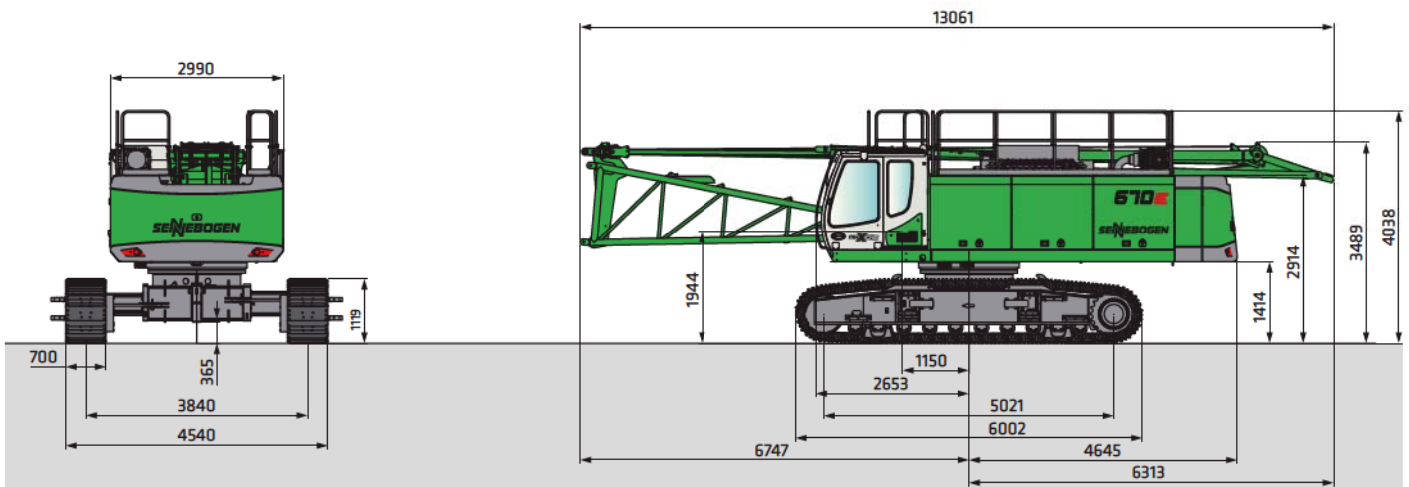



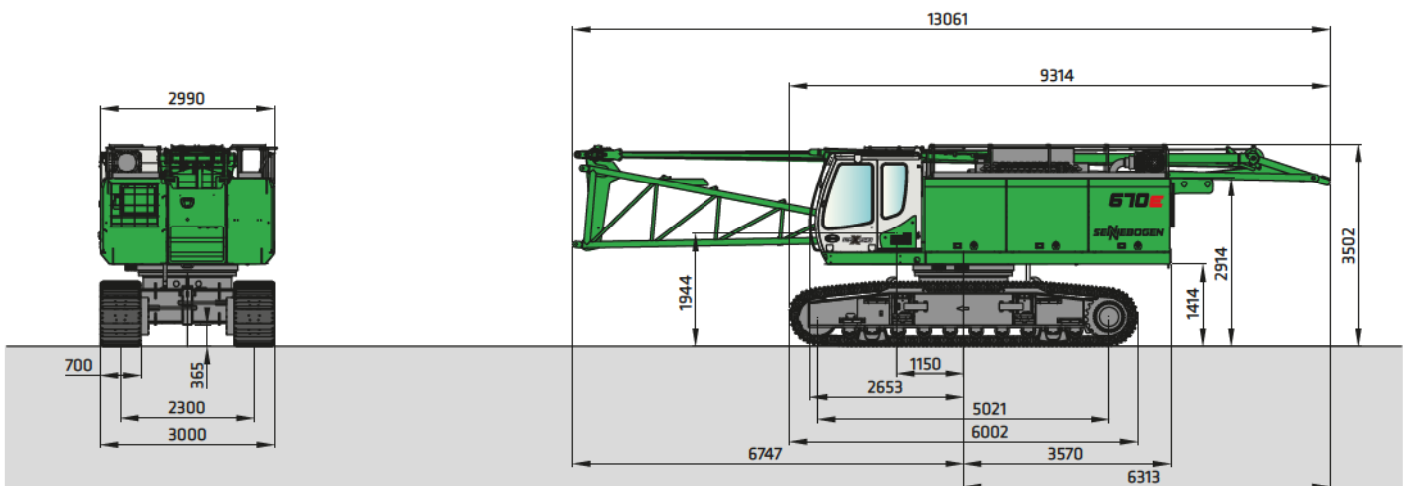



670 R with counterweight 22 t, telescopic undercarriage T83/990, lower boom section, 2 x 16 t freefall winch, approx 67.8 t

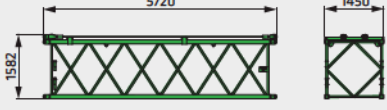
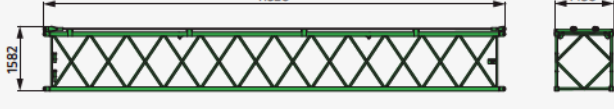
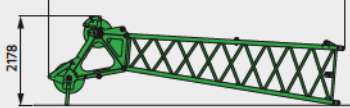

670 HD without counterweight, lower boom section 2 x 16 t free-fall winch, approx. 45.8 t

670E Transport dimensions

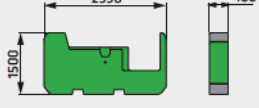
HD

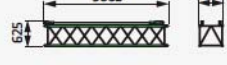
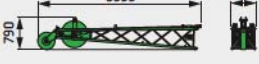
	<p>Lower boom section 5.5 m, type 1442</p> <p>Weight: 2,000 kg (can vary due to supplementary equipment)</p>
	<p>Intermediate boom section 2.8 m, type 1442</p> <p>Weight: 400 kg</p>
	<p>Intermediate boom section 5.6 m, type 1442</p> <p>Weight: 650 kg</p>
	<p>Intermediate boom section 11.2 m, type 1442</p> <p>Weight: 1130 kg</p>
	<p>Boom headpiece 6.6 m, type 1442</p> <p>Weight: 1600 kg</p>
	<p>Auxiliary jib S 12.4</p> <p>Weight: 410 kg</p>
	<p>Counterweight</p> <p>Weight: 10,000 kg</p>
	<p>Counterweight</p> <p>Weight: 12,000 kg</p>
	<p>Fly boom lower section 3m, type 598</p> <p>Weight: 330 kg</p>
	<p>Fly boom intermediate section 3m, type 598</p> <p>Weight: 120 kg</p>
	<p>Fly boom head piece 3m, type 598</p> <p>Weight: 210 kg</p>

670E Ballast installation system

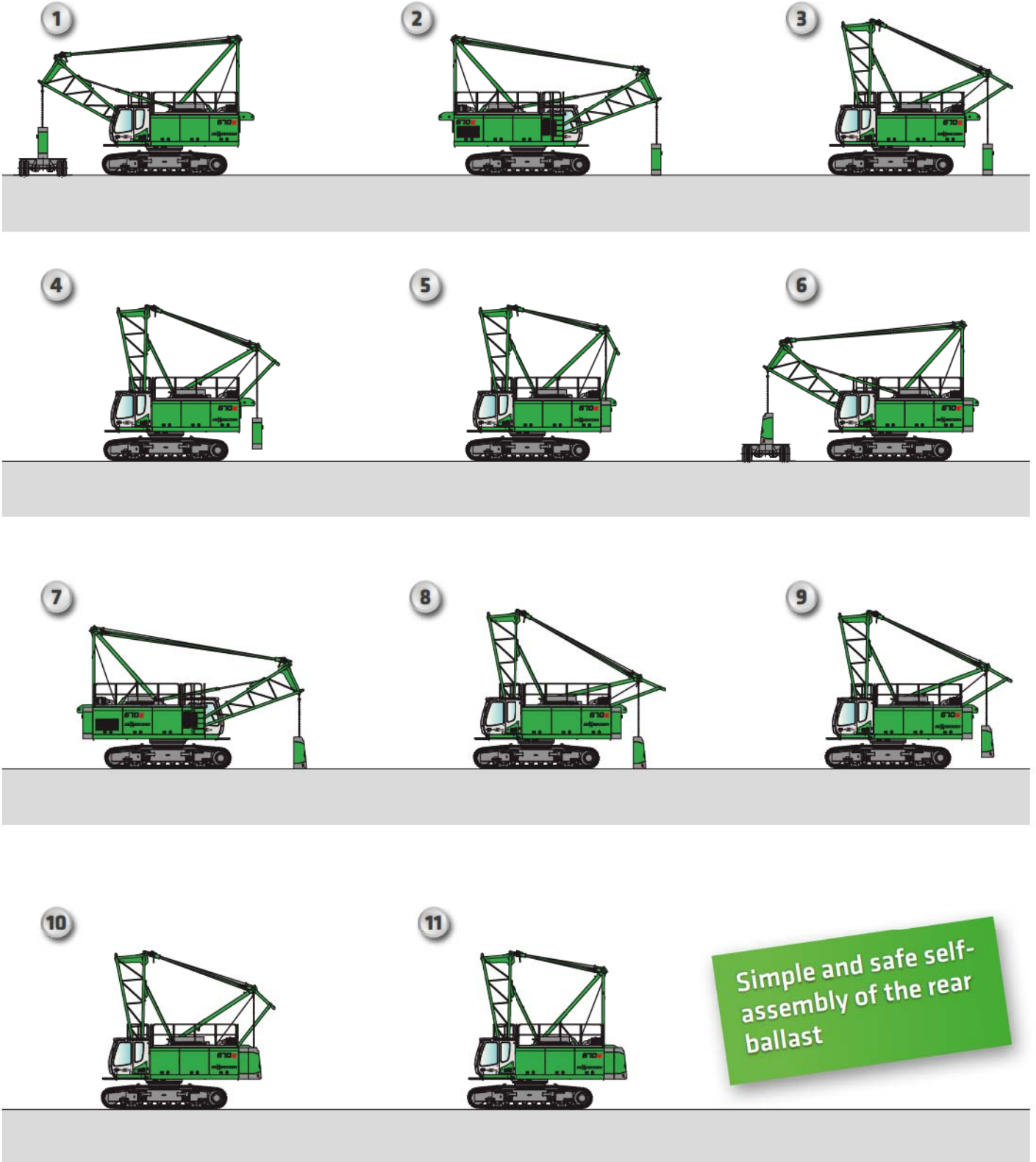

Simple and safe self-assembly of the rear ballast

670E Notes

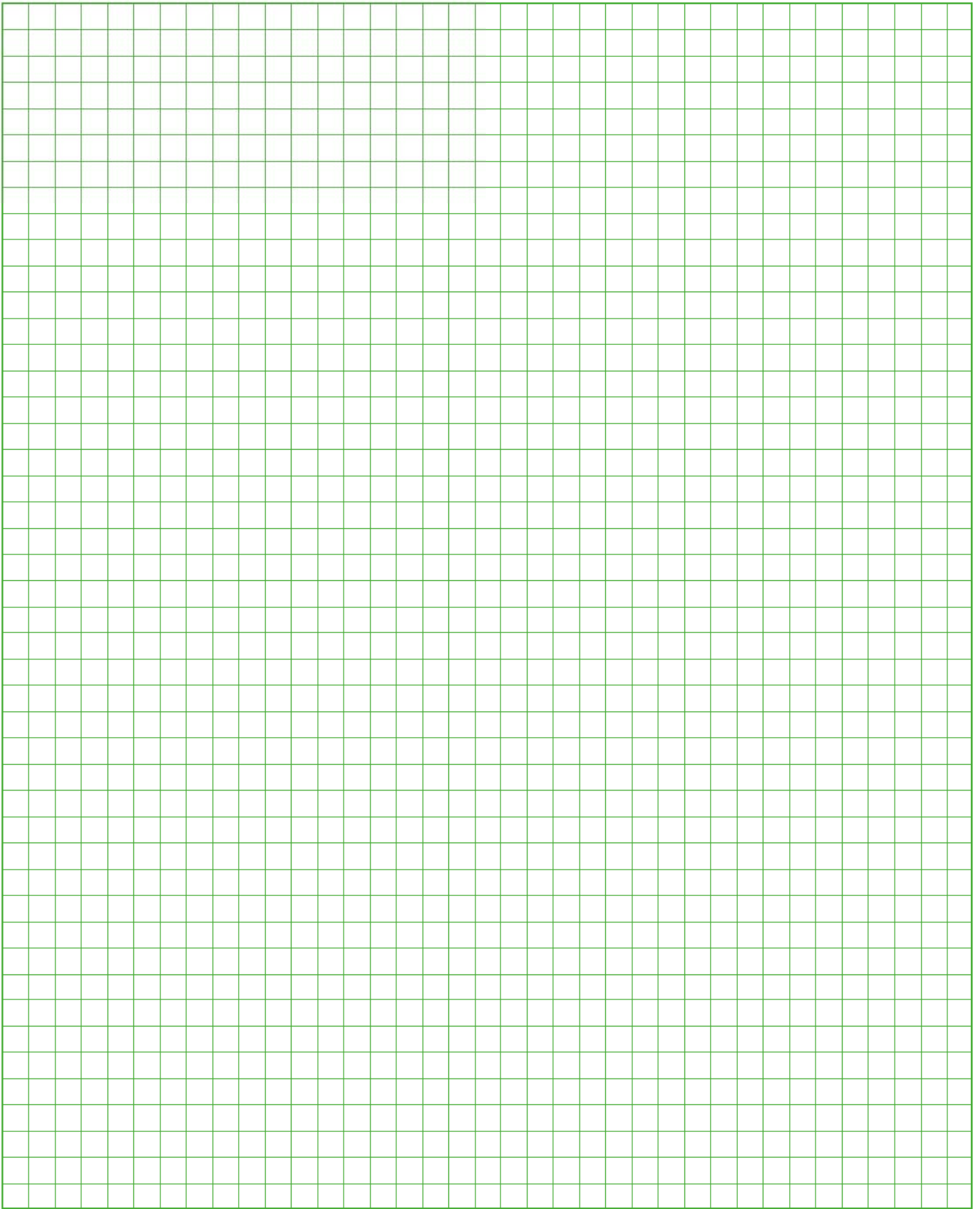

670E Notes

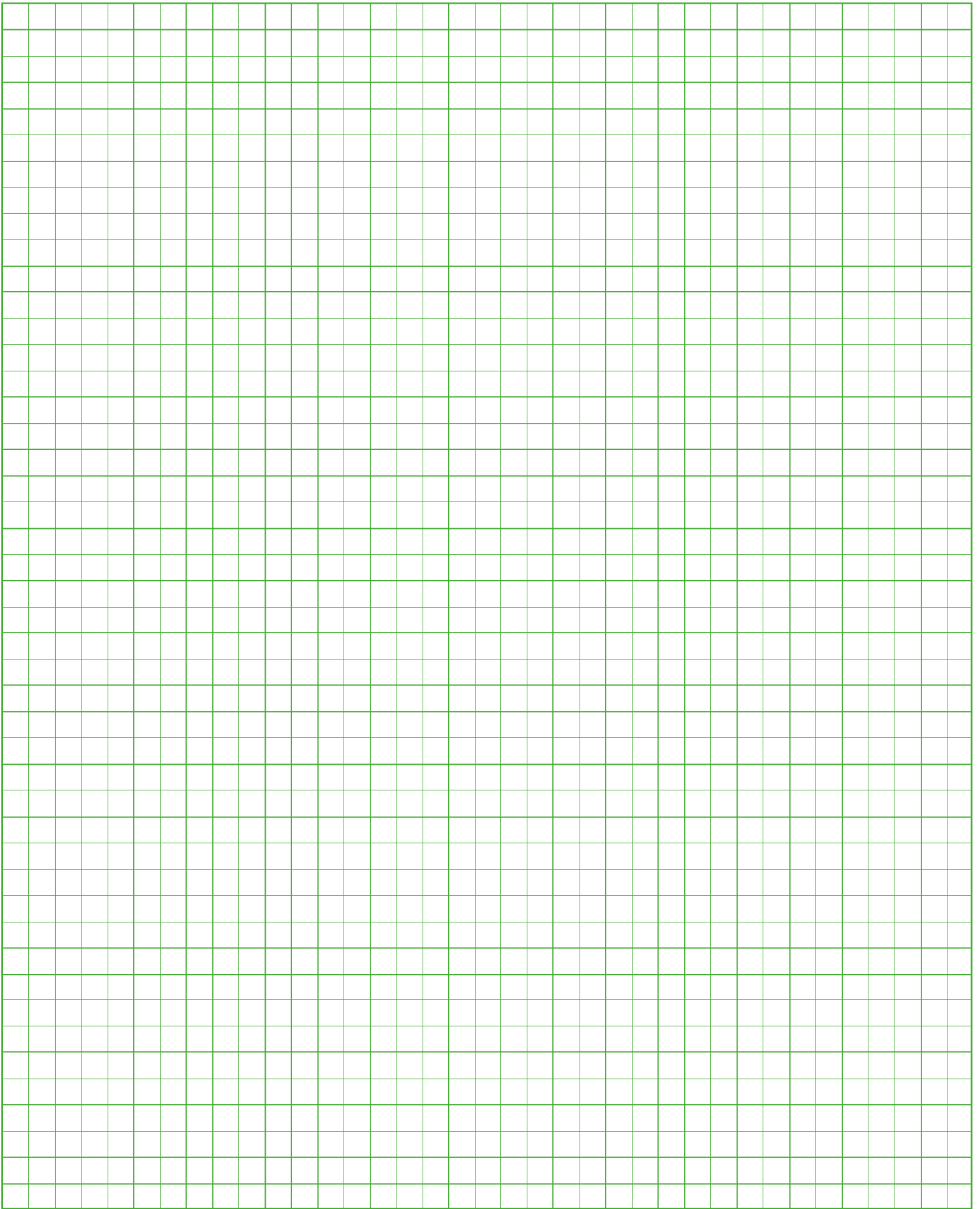

670E Notes

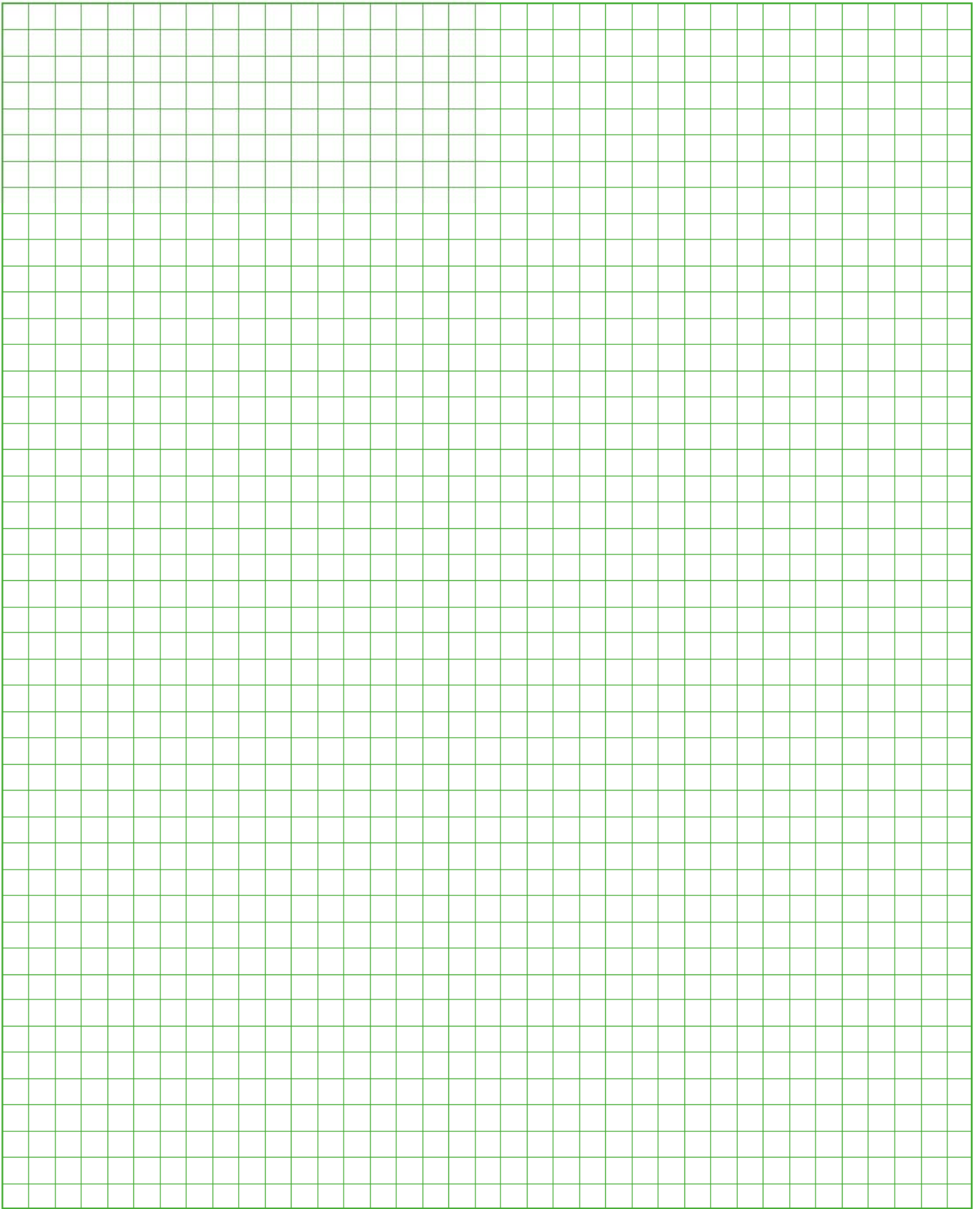

670E

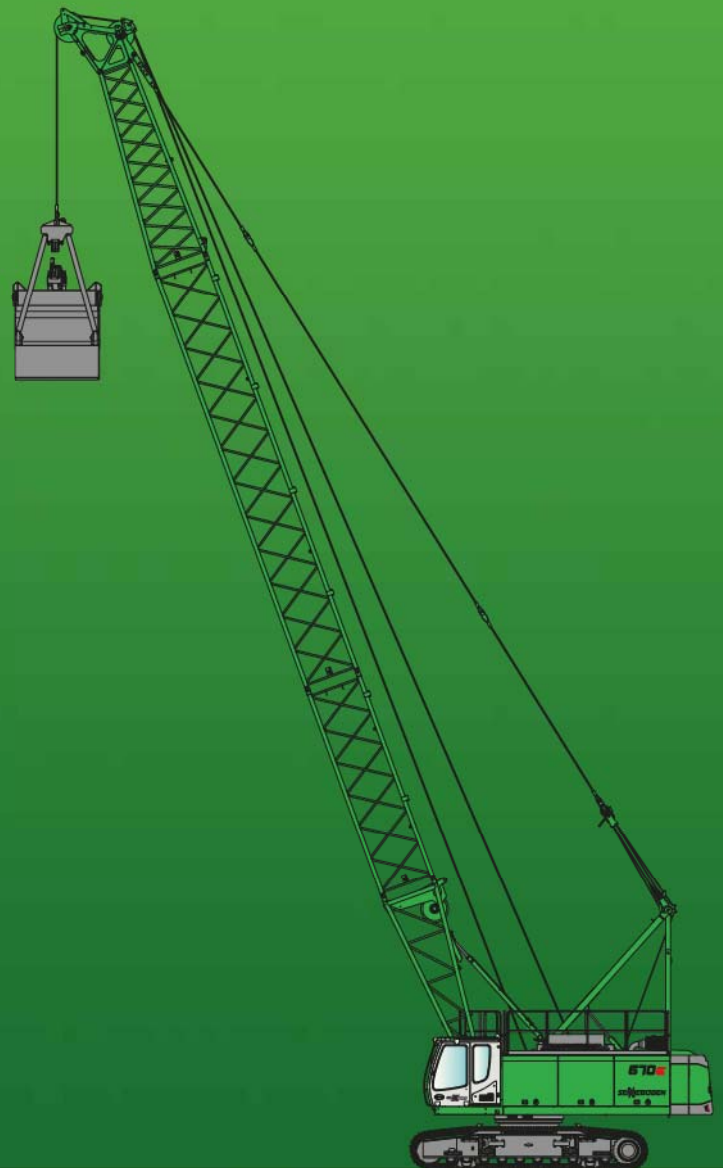

This catalog describes machine models, scopes of equipment of individual models, and configuration options (standard equipment and optional equipment) of the machines supplied by SENNEBOGEN Maschinenfabrik. Machine illustrations can contain optional equipment and supplemental equipment. Actual equipment may vary depending on the country to which the machines are delivered, especially in regard to standard and optional equipment.

All product designations used may be trademarks of SENNEBOGEN Maschinenfabrik GmbH or other supplying companies, and any use by third parties for their own purposes may violate the rights of the owners.

Please contact your local SENNEBOGEN sales partner for information concerning the equipment variants offered. Requested performance characteristics are only binding if they are expressly stipulated upon conclusion of the contract. Delivery options and technical features are subject to change. Errors and omissions excepted. Equipment is subject to change, and rights of advancement are reserved.

© SENNEBOGEN Maschinenfabrik GmbH, Straubing/Germany. Reproduction in whole or in part only with written consent of SENNEBOGEN Maschinenfabrik GmbH, Straubing, Germany.

SENNEBOGEN

SENNEBOGEN
Maschinenfabrik GmbH
Sennebogenstraße 10
94315 Straubing, Germany

Tel. +49 9421 540-144/146
Fax +49 9421 43 882
marketing@sennebogen.de

Order no. / Item no. 299121
670R-E-051710

GO FOR GREEN

 www.sennebogen.com