

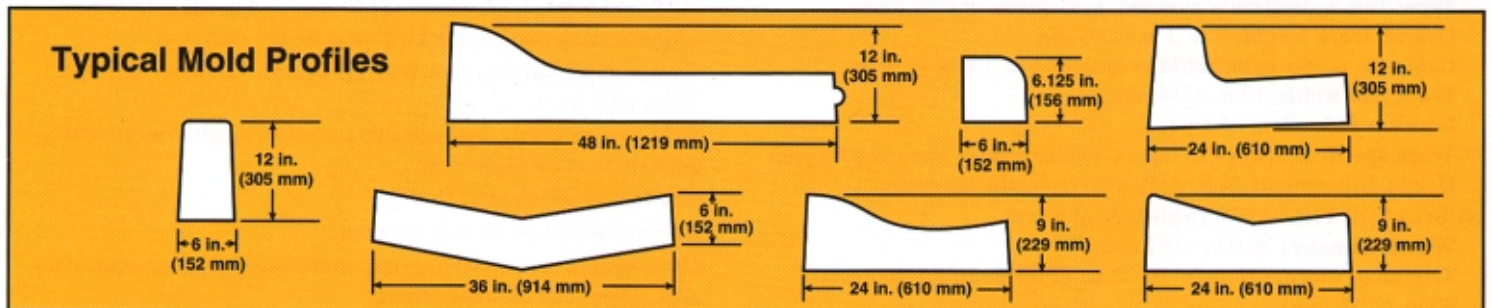

GT-6000 TRIMMER/PAVER



HIGH-PRODUCTION SLIPFORM PAVER, USING THE PATENTED, SIMULTANEOUS TRIM/POUR CONCEPT

- The GOMACO GT-6000, available in two models, provides built-in versatility for handling a variety of slipform paving projects. Excellent job-to-job mobility by means of a standard trailer and a pick-up. Simultaneous trim/pour concept assures virtually 100 percent concrete yield in a single-pass operation with operating speeds up to 32 fpm (9.75 mpm).
- Model GT-6000-78 has a trimming width of 78 in. (1981 mm) with paving widths up to 4 ft. (1.22 m) and model GT-6000-90 has a trimming width of 90 in. (2286 mm) with paving widths up to 5 ft. (1.52 m). Capable of trimming and pouring 25 ft. (7.62 m) cul-de-sacs and radii of 15 ft. (4.57 m).
- Two crawler tracks provide durability and high performance.
- Internal trimmerhead drive minimizes side clearance, permits trimming to within 3 in. (76 mm) of obstacles to a tolerance within one-eighth inch (3 mm) to grade.
- Automated single-point electronic sensing system controls grade, steering and cross slope.
- Capable of accommodating a sidemounted mold for specific job conditions. Molds are quickly interchangeable.
- Ideal for slipforming curb and gutter, sidewalk, recreational trail and small irrigation canal.

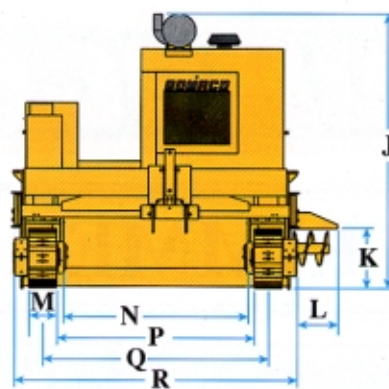
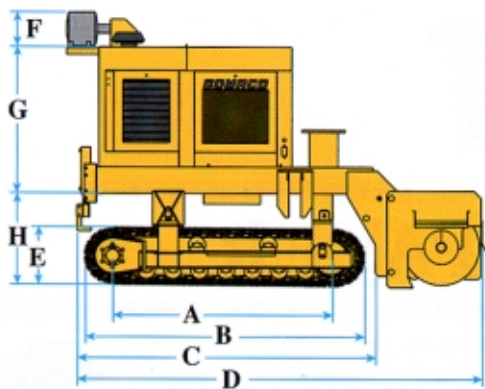

BOTH MODELS

A. 6 ft. 5.8 in. (1.98 m)	G. 4 ft. 3.3 in. (1.30 m)
B. 8 ft. 2 in. (2.49 m)	H. 32.2 in. (818 mm)
C. 8 ft. 8.5 in. (2.65 m)	J. 8 ft. (2.44 m)
D. 11 ft. 10 in. (3.61 m)	K. 21.2 in. (538 mm)
E. 20.3 in. (516 mm)	L. 14.3 in. (363 mm)
F. 12.2 in. (310 mm)	M. 10 in. (254 mm)

MODEL GT-6000-78

N. 4 ft. 4.8 in. (1.34 m)
P. 4 ft. 9.4 in. (1.46 m)
Q. 5 ft. 7.2 in. (1.71 m)
R. 7 ft. 3.4 in. (2.22 m)

MODEL GT-6000-90

N. 5 ft. 4.8 in. (1.65 m)
P. 5 ft. 9.4 in. (1.76 m)
Q. 6 ft. 7.2 in. (2.01 m)
R. 8 ft. 3.4 in. (2.52 m)

ENGINE

Type: Cummins diesel.
Power: 92 hp (68.6 kW) @ 2100 rpm.

SERVICE CAPACITIES

Fuel reservoir: 50 gal. (189.3 L).
Oil reservoir: GT-6000-78, 117 gal. (442.9 L); GT-6000-90, 123 gal. (465.6 L).

HYDRAULIC SYSTEM

Pumps: One double-stage and one single-stage main pump provide 66 gpm (249.8 Lpm) @ 2000 rpm. One pressure-compensated lift-control pump provides 11 gpm (41.6 Lpm).
Oil cooler: Forced air.
Filtration: Industry standard filtration, including two micron control-circuit filters, and 100 wire mesh lift-circuit strainers and suction sump strainers.

VIBRATORS

Type: Three hydraulic vibrator circuits and controls. GT-6000-78, two hydraulic vibrators; GT-6000-90, three hydraulic vibrators.

SLIPFORM MOLD

Curb and gutter mold: One mold standard, up to 36 in. (914 mm) wide. Optional molds available.

AUTOMATIC CONTROL SYSTEM

Type: Electronic-over-Hydraulic.
Controls: Proportional control system with front grade, steering and cross-slope controls.

TRACK SYSTEM

Type: Two hydraulically powered, gear-driven crawler tracks.
Overall track length: 8 ft. 2 in. (2.49 m).
Center-to-center sprocket/idler length: 6 ft. 5.8 in. (1.98 m).
Track pad width: 10 in. (254 mm).
Gearbox reduction: 36.64:1.
Track speed: 32 fpm (9.75 mpm); auxiliary @ 48 fpm (14.63 mpm).
Height adjustment: 14 in. (356 mm) hydraulic leg stroke.

SUBGRADE TRIMMER (with internal drive)

Wheel diameter: 26.8 in. (681 mm).
Trimming width: GT-6000-78, 78 in. (1981 mm); GT-6000-90, 90 in. (2286 mm).

MANUFACTURED UNDER ONE OR MORE OF THE FOLLOWING U.S. OR FOREIGN PATENTS: 3,299,786; 3,450,011; 3,541,931; 3,779,661; 3,959,977; 4,073,592; 4,136,993; 4,226,917; 4,343,513; 4,360,293; D-266,850; 853,607; 861,819; 954,773; 406,787; 1,147,187; 133,220; D-512,249; 4,717,282; 4,457,645; C-1,110,893; C-1,191,044; 12,890-1-0010; 5,061,115; 7,509,187; 7,509,615; 5,102,267; 5,101,360; 4,954,019; 4,984,639; 5,190,397; 5,209,602; 0,518,535; 2,067,126; 494,257; 69,031,836.7-08 AND PATENTS PENDING.

GOMACO Corporation reserves the right to make improvements in design, material, and/or changes in specifications at any time without notice and without incurring any obligation related to such changes.

Printed in U.S.A. © 1998 (12 AP) GOMACO Corporation Order #0300-0A10108

Worldwide Headquarters

GOMACO Corporation
 GOMACO International
 119 East Highway 175, PO Box 151
 Ida Grove, IA USA 51445
 Ph: 712-364-3347
 Fax: 712.364.3986
 E-mail: info@gomaco.com

GOMACO International Ltd.

769 Buckingham Avenue
 Trading Estate, Slough
 SL1 4NL Berkshire, England
 Ph: 44-1753-821926
 Fax: 44.1753.693093

DIMENSIONS (shipping & operational)

Length: 11 ft. 10 in. (3.61 m).

Height: 8 ft. (2.44 m).

Widths: Shipping width is 7 ft. 3.4 in. (2.22 m) for the GT-6000-78 and 8 ft. 3.4 in. (2.52 m) for the GT-6000-90.

Operational width is 8 ft. 5.7 in. (2.58 m) for the GT-6000-78 and 9 ft. 5.7 in. (2.89 m) for the GT-6000-90.

Paving widths

Maximum sidewalk width: GT-6000-78, 4 ft. (1.22 m); GT-6000-90, 5 ft. (1.52 m).

Maximum curb and gutter width: GT-6000-78, 3 ft. 7 in. (1.09 m); GT-6000-90, 4 ft. 7 in. (1.40 m).

***Maximum curb height:** 18 in. (457 mm) for both models.

***Profiles over 18 in. (457 mm) require two track-lowering kits and a trimmerhead-lowering kit, consult factory.**

WEIGHTS

Shipping weight: GT-6000-78, 12,200 lbs. (5533.9 kg); GT-6000-90, 13,100 lbs. (5942.2 kg).

OPTIONS

Network control system, self-diagnostic system for grade and steering.

Additional hydraulic vibrator and mount.

Water system, includes 65 gal. (246.1 L) tank, hydraulically driven water pump, hose and nozzle.

Sidemount curb and gutter assembly.

Track-lowering kits, 6 in. (152 mm), 9 in. (229 mm) and 12 in. (305 mm) single track-lowering kit. For paving adjacent to existing concrete, centermount, use kit closest to slab thickness.

Trimmerhead-lowering kits, 6 in. (152 mm), 9 in. (229 mm) and 12 in. (305 mm).

Hold-over assembly, hydraulically powered, required when paving adjacent to existing concrete.

Slipform molds, consult factory.

Rubber track pads, 84 pads required.

Other options are available to customize machine to accommodate applications and customer needs.



The Worldwide Leader in Concrete Paving Technology

GOMACO International
 Singapore Representative Office
 02-02 Heritage, 4 Ardmore Park
 Singapore 259960
 Ph: 65-738-8481
 Fax: 65.235.6837
 E-mail: tnash@pacific.net.sg

GOMACO International Australia
 46 Park Avenue
 Clayfield 4011
 Brisbane, Queensland
 Australia
 Ph: 61-07-3857-6377
 Fax: 61-07.3857.6311